

MATERIAL or METHODS Specifications

ISSUE: 0

MODEL:VM6ZK273H

NUMBER:

120803

1. OPERATING SCOPE/适用范围

THIS SPECIFICATIONS APPLY TO MOTOR MODEL 6ZK273H.

该产品说明书适用型号 6ZK273H 电机。

2. OPERATING CONDITIONS/使用条件

NO	ITEMS/项目	SPECIFICATIONS/规定
2-1	RATED VOLTAGE/额定电压	3.0V DC
2-2	OPERATING VOLTAGE/使用电压 范围	1.7 ~ 3.6V DC
2-3	RATED LOAD/额定负荷	COUNTERWEIGHT (ACCORDING TO SPECIFICATION OF MOTOR HOUSING CONFIGURATION)/摆锤重 (按电机外形结构 图规定)
2-4	ROTATION/旋转方向	C.W. (CLOCKWISE)/顺时针旋转
2-5	MOTOR POSITION/电机位置	ALL DIRECTION/全方向
2-6	OPERATING CONDITIONS/使用 环境	-20°C ~ 60°C, ORDINARY HUMIDITY/ 10 ~ 90%RH
2-7	STORAGE CONDITIONS/贮存环 境	-20°C ~ 80°C, ORDINARY HUMIDITY/ 5 ~ 95%RH(NO CONDENSATION OF MOISTURE/不凝露)

3. MEASURING CONDITIONS/测试条件

NO	ITEMS/项目	SPECIFICATIONS/规定
----	----------	-------------------

MATERIAL or METHODS Specifications

ISSUE: 0

MODEL: VM6ZK273H

NUMBER:

120803

3-1	TEMPERATURE/温度	20±2°C
3-2	HUMIDITY/湿度	(65±5%)RH
3-3	MOTOR POSITION/电机状态	MOTOR SHAFT HORIZONTAL (LOCK THE MOTOR IN A TEST FIXTURE)/输出轴水平 (电机固定在测试夹具中)

ALL DATA ARE BASED ON THE MEASURING CONDITIONS: TEMPERATURE, 20°C; HUMIDITY, 65%RH.
IF ANY DISAGREEMENT OCCURS, SUCH TEST CONDITIONS ARE AVAILABLE: TEMPERATURE, 5 ~ 35°C; HUMIDITY, 45 ~ 85%RH./

所有数据的测试条件为：温度 20°C，相对湿度 65%RH。如果有任何不一致出现，在以下条件中测试也是可以的：温度 5 ~ 35°C；湿度 45 ~ 85%RH。

4. APPEARANCE SPECIFICATION/外观性能要求

NO	ITEMS/项目	SPECIFICATIONS/规定	CONDITION REMARK/条件、备注
4-1	CONFIGURATION/ 结构尺寸	ACCORDING TO SPECIFICATION OF MOTOR HOUSING CONFIGURATION/ 按电机外形结构图规定	DEPENDENT ON FIGURE 1/按照图 1
4-2	APPEARANCE/ 外观	THERE SHALL BE NO EVIDENCE OF MECHANICAL DAMAGE AND SHALL BE NO INADEQUATE CORROSION, ETC./没有机械的损害痕迹，并且也没有腐蚀痕迹，等。	VISUAL EXAMINATION:(ALLOWABLE EXTENT IN BASED ON BOUNDARY SAMPLE).目视检查(允许范围和限度见样品)
4-3	WEIGHT/重量	1.85±0.2g	

5. MECHANICAL PERFORMANCE AND CHARACTERISTICS/机械性能和特性 (AT ITEM 3 MEASURING CONDITION/按第 3 项的测试条件测试)

MATERIAL or METHODS Specifications

ISSUE: 0

MODEL: VM6ZK273H

NUMBER:

120803

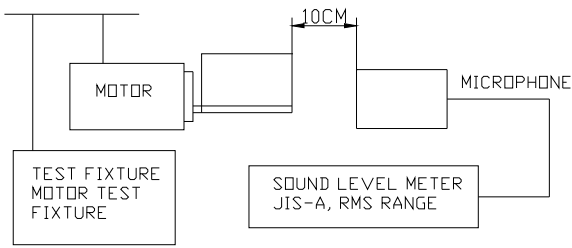
NO	ITEMS/项目	SPECIFICATIONS/规定	CONDITION REMARK/条件、备注
5-1	RATED SPEED /额定转速	14000±2000 rpm/min	AT RATED VOLTAGE AND RATED LOAD (COUNTERWEIGHT)/在额定电压, 额定负荷下 (摆锤重)
5-2	RATED CURRENT/额定电流	75 mA(MAX)	
5-3	STALL CURRENT/堵转电流	140 mA(MAX)	AT RATED VOLTAGE AND SHAFT LOCK./在额定电压下输出轴堵转
5-4	STARTING VOLTAGE/起动电压	1.7V DC (MAX)	AT RATED LOAD (COUNTERWEIGHT) ANY POSITION OF ROTOR./在额定负荷下转子的任一位置。
5-5	INSULATION RESISTANCE/绝缘强度	1MΩ (MIN)	AT DC 100V BETWEEN THE LEAD WIRES OR REED AND MOTOR HOUSING./在导线 (或簧片) 和马达机身之间加 100V 的直流电压。
5-6	ARMATURE RESISTANCE/电枢电阻	24±20%Ω	AT 20°C
5-7	MECHANICAL NOISE/机械噪音	45dB (MAX)	
		<p>MEASURED AT RATED VOLTAGE AND RATED LOAD (COUNTERWEIGHT) 在额定电压, 额定负荷 (摆锤重) 下测试</p> <p>BACKGROUND NOISE 28dB (MAX)/背景噪音最大为 28dB.</p> <p>LOCK THE MOTOR IN A TEST FIXTURE (SHAFT HORIZONTAL) 电机固定在测试夹具中 (输出轴水平) SUSPENSORY METHOD/悬吊方式</p>	
			

6. RELIABILITY TEST/可靠性测试

NO	ITEMS/项目	STANDARD TEST CONDITIONS/标准试验条件	REQUIREMENTS/判定特性

MATERIAL or METHODS Specifications

ISSUE: 0

MODEL: VM6ZK273H

NUMBER:

120803

6-1	LIFE TEST/ 寿命试验	VOLTAGE /电压 : 3.0V DC LOAD /负荷 : COUNTERWEIGHT (摆锤重) TEMPERATURE/温度 : 20°C±2°C HUMIDITY/湿度 : 65±5%RH LOCK THE MOTOR IN A TEST FIXTURE (SHAFT HORIZONTAL) /电机固定在试验夹具中 (输出轴水 平)	AFTER THE TEST, MOTORS SHALL BE SATISFY WITH SPECIFIED IN TIEM 7-1./试验后, 应满足 7-1 项要求.
		TEST MODEL/试验形式 : 2S ON (C.W), 2S (OFF) TEST TIME /试验时间 : 50,000CYCLES	
6-2	LOW TEMP STORAGE/ 低温 存放试验	TEMPERATURE/温度 : -20°C±2°C TIME/时间 : 96 HOURS	AFTER 2 HOURS PLACED IN ORDINARY TEMPERATURE AND HUMIDITY , MOTORS SHALL BE SATISFY WITH SPECIFIED IN ITEM 7-1./常 温常湿中放置 2 小时后, 测试 应满足 7-1 项要求。
6-3	HIGH TEMP STORAGE/ 高温 存放试验	TEMPERATURE/温度 : 80°C±2°C TIME/时间 : 48HOURS	
6-4	HUMIDITY STORAGE/ 湿度 存放试验	TEMPERATURE/温度 : 70°C±2°C HUMIDITY/湿度 : 90 ~ 95%RH TIME/时间 : 240 HOURS NO CONDENSATION OF MOISTURE/不凝露	

MATERIAL or METHODS Specifications

ISSUE: 0

MODEL: VM6ZK273H

NUMBER:

120803

6-5	TEMPERATURE SHOCK/ 温度冲击	<p>60°C±2°C -10°C±2°C</p>  <p>TEST DURATION/试验持续时间 : 32CYCLES TRANSITION TIME/转换时间 : 20S</p>	<p>AFTER 24 HOURS PLACED IN ORDINARY TEMPERATURE AND HUMIDITY , MOTORS SHALL BE SATISFY WITH SPECIFIED IN ITEM 7-1./常 温常湿中放置 24 小时后 , 测 试应满足 7-1 项要求</p>
6-6	VIBRATION TEST /振动试验	<p>TOTAL PEAK AMPLITUDE /全振幅 : 1.5mm (P-P) FREQUENCY/频率 : 233HZ PERIOD/周期 : 10-55-10HZ DIRECTION/方向 : X , Y , Z TEST TIME/试验时间 : 30 MINUTES PER PLANE/每阶段 30 分钟</p>	
6-8	DROP TEST/ 跌落试验	<p>SET THE MOTOR ON THE HEAVY BLOCK ABOUT 100g WEIGHT (INCLUDE THE MOTOR) AND DROP THE MOTOR ON THE CONCRETE FLOOR./电机放在大约 60g (包括电机) 重的物体上自由落体到水泥地板上。 HEIGHT/高度 : 1.5m DIRECTION/方向 : ±X , ±Y , ±Z TIMES/次数:TWO DROPS PER PLANE FOR A TOTAL OF 12 DROPS/每一平面下落 2 次 , 共计 12 次</p>	<p>AFTER THE TEST, MOTORS SHALL BE SATISFY WITH SPECIFIED IN TIEM 7-1./试验后 , 应满足 7-1 项要求.</p>

7. REQUIREMENTS/判断特性

NO	ITEMS/项目	REQUIREMENTS/判定特性
7-1	TABLE A	<p>1)LOAD SPEED VARIES WITHIN ±30% FROM INITIAL./负载转速的变化应在初始值的±30%内 ;</p>

MATERIAL or METHODS Specifications

ISSUE: 0

MODEL:VM6ZK273H

NUMBER:

120803

		2)LOAD CURRENT VARIES WITHIN $\pm 30\%$ FROM INITIAL./负载电流的变化应在初始值的 $\pm 30\%$ 内 ; 3)TERMINAL RESISTANCE VARIES WITHIN $\pm 30\%$ FROM INITIAL./端子间的电阻变化应在初始值的 $\pm 30\%$ 内 ; 4)STARTING VOLTAGE IS 1.8 V MAX./起动电压的最大值为 1.8V.
--	--	--

8. PACKAGE REQUIRE/包装要求

CONTENT AND PROCESS/工作内容和程序

1.50 OR 100 VIBRATORS IN EACH PLASTIC CAPSULE./每个吸塑盒里放 50 或 100 个马达。

2.EVERY 10 CAPSULES AS A GROUP, PUT A PLASTIC COVER ON THE GROUP AND WRAP IT IN TAPE./每 10 个吸塑盒上盖一个吸塑盖板，用胶带捆做一捆。

3.PUT THE WRAPPED GROUP INTO A PLASTIC BAG AND WRAP THE BAG./捆好后装入塑料袋内用胶带绑好。

4.EVERY 8 BAGS ARE PUT INTO AN OUTER CASE WITH A SIZE OF 500×310×420 BY THE WAYS STIPULATED AS THE DRAWING./每 8 袋吸塑盒按图中的叠放方式放入一个外包装箱 (500×310×420)。

5.QUANTITY AND BATCH NUMBER ARE WRITTEN ON THE SURFACE OF THE OUTER CASE./数量、生产批号均写在外包装箱上。

MATERIAL or METHODS Specifications

ISSUE: 0

MODEL:VM6ZK273H

NUMBER:

120803

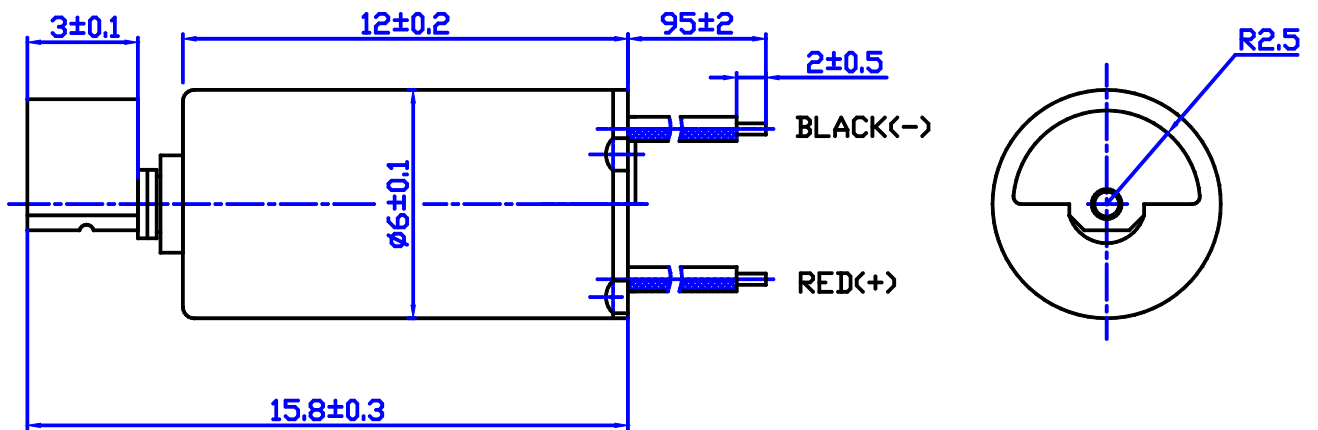

Figure 1 Motor Housing Configuration

图 1 电机外形结构图